



Stretch Wrapper
CTT 200



Stretch Wrapper CTT 200

Designed for low volume users and for pre stretched films. Wraps irregular shaped loads. Uses forklift/palletjack to load stretch wrapper. Operator starts wrap cycle at machine. Operator manually cuts/attaches film.

These properties guarantee good load securement and transport packaging.



Standard machine specification and dimensions

Machine	Table diam	Ø1650 mm
	Speed	Up to 12 rpm adjustable
	Start / stop	Frequency controlled
	Bottom/ top wraps	1–7 (Prog 3, 2-14)
	Film carriage speed	Variable speed
	Film tension	Adjustable friction brake
	Stretch wrapping programs	5 standard
	Controller	PLC
Power	Supply	Single phase 240V 50 Hz
	Protection	IP54
	Loading	10 A
Pallet Goods	Max size (length x width)	1200 x 1000 mm
	Max. goods height incl. pallet:	2200 mm
	Permitted load weight	2000 Kg
Stretch Film	Core diameter	76 mm
	Outer diameter, max	250 mm
	Film width, max	500 mm
	Film thickness	9-35 my

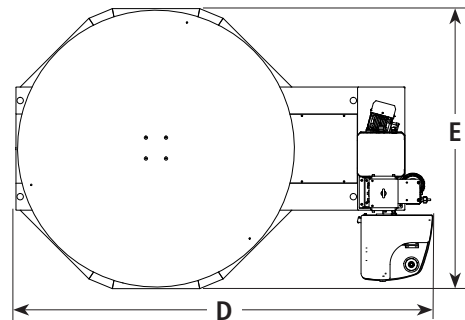
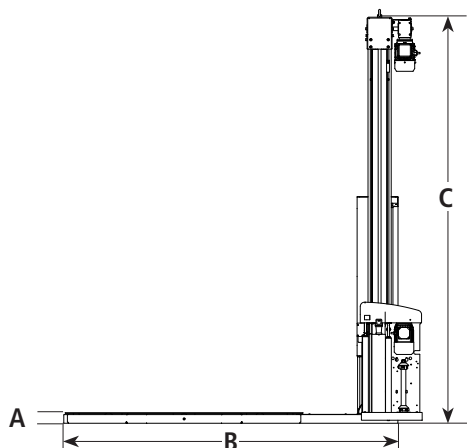

Dim (mm)	A	B	C	D	E
Standard	73	2305	2800	2475	1660

Weight, standard: 380 kg (Weight can vary depending on options). Crated dimensions: L2900 x H750 x W1700 mm, weight: 550 kg.

WWW.CYKLOPTEKNIK.SE

CYKLOP[®]
GLOBAL PACKAGING SOLUTIONS

STRAPPING
WRAPPING
CODING
TAPING